

How To Fly

1



Download **Loolinn Air** App

2

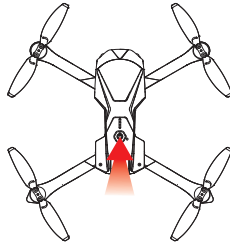

3

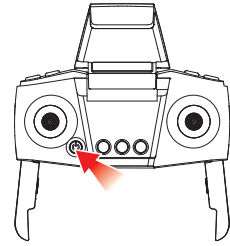

4

push up

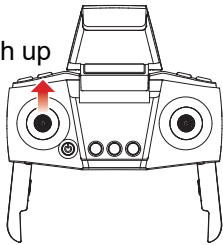

5

push down

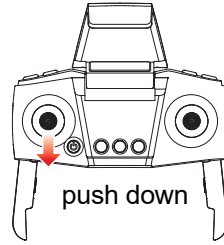

6

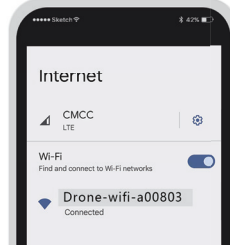

7

Compass Calibration

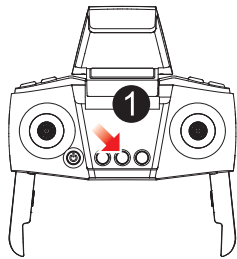

Press 2 seconds

2

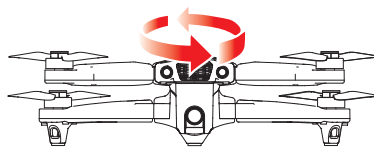

Horizontally rotate 360°
Until Indicator quick flash

3

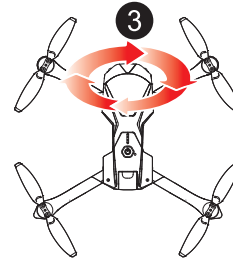

Vertically rotate 360°
Until Indicator solid on

8

Level/Gyroscope Calibration

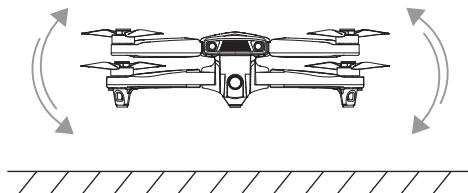

Put the drone on level ground

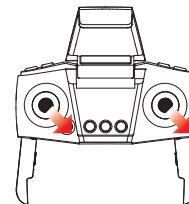

Push both joysticks to the lower right corner and hold for about 3 seconds

9

Take Off

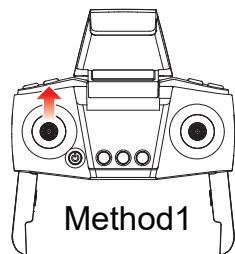

Method1

or

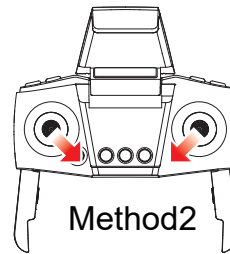

Method2

10

Landing

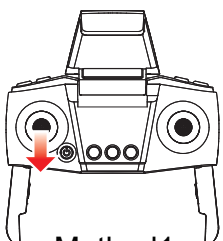

Method1

or

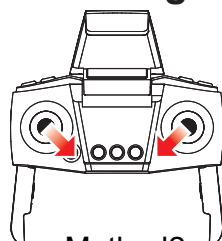

Method2

or

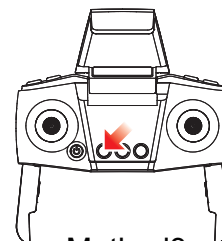

Method3

Flight Direction Control

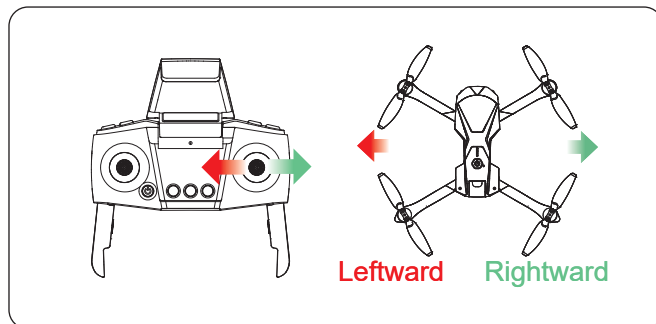
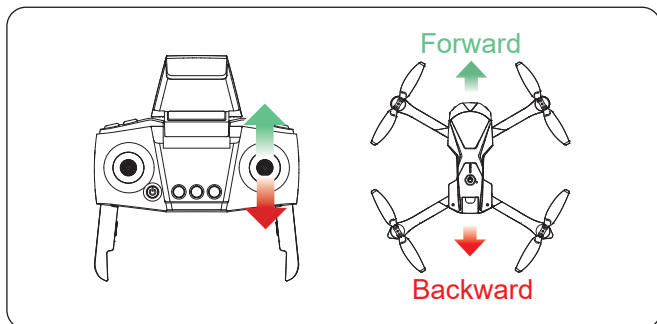
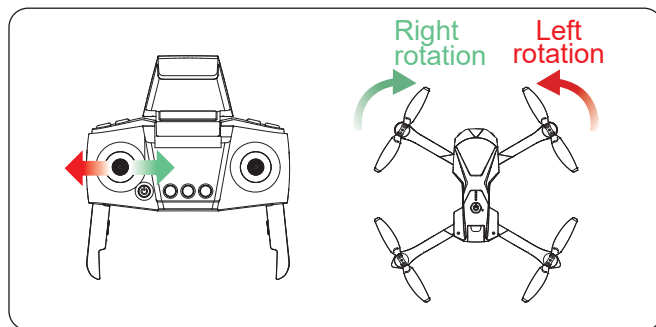
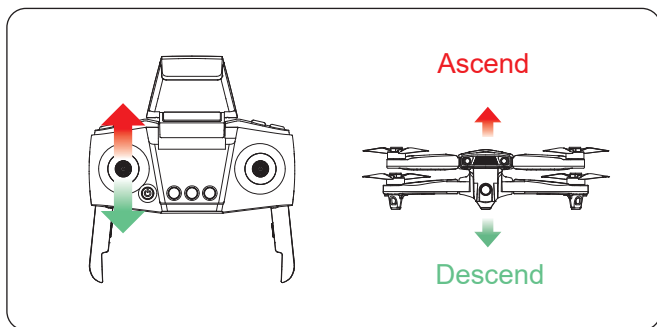

Remote Control

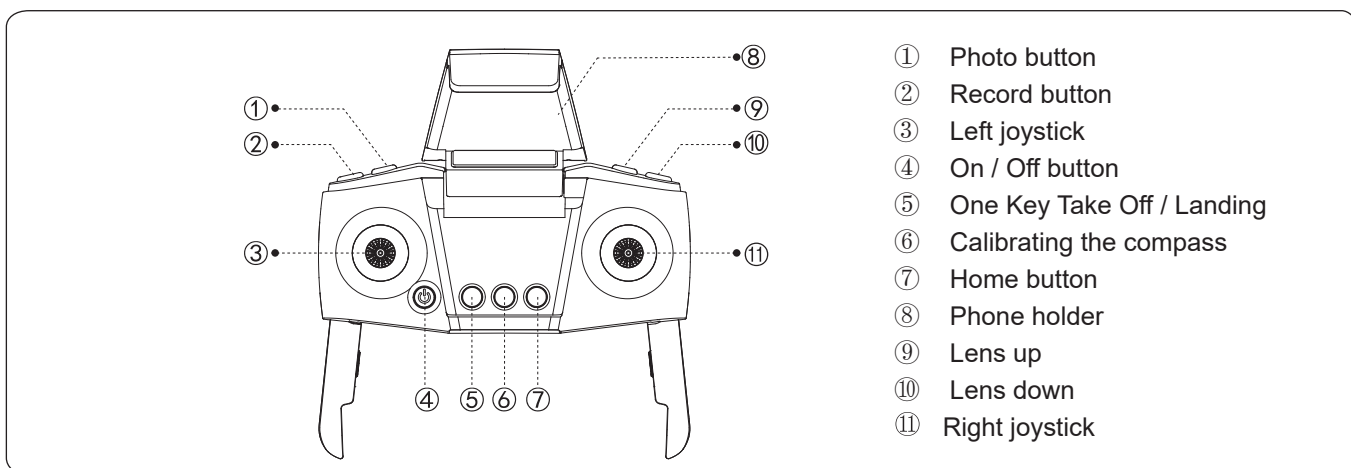

App Control

